

ATELIER :

La Motrice Paysage et Urbanisme, Hugo RECEVEUR

+ Kristof GUEZ, artiste

+ Yannick DELMAS, animateur et artisan-murailler

Charte de design d'espace, d'objet et de signalétique

“Designer” le territoire

Deux types de sites : 2 rythmes, 2 échelles...

Un travail de filiation contextuelle (fil d'ariane, ligne directrice...)

Une intimité à préserver et à scénographier

Des modèles de mobilier simples et répétés

Une gestion poétique des rythmes de fréquentations

Deux types de sites, et des déclinaisons selon les moyens

1 - sites "phare" : espaces publics, carrefours de pays, lieux de spectacles et d'accueil de groupes, visibilité, ludique

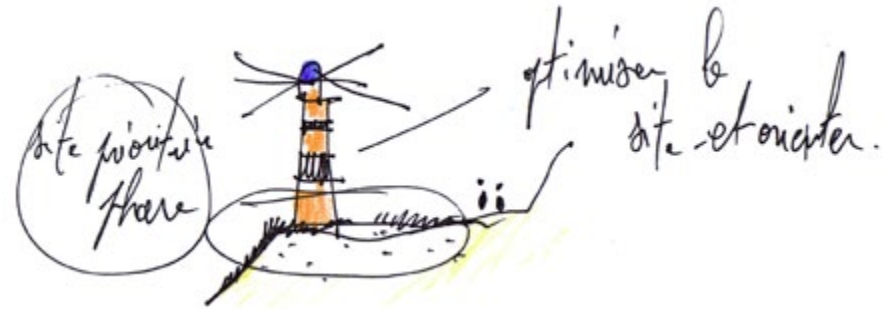

Lac Labarthe, Parisot, Escale Guépienne, pôle gare...

2 - sites "balise" : espace collectif, bivouac, intimité, fluidité, sauvage, aventure

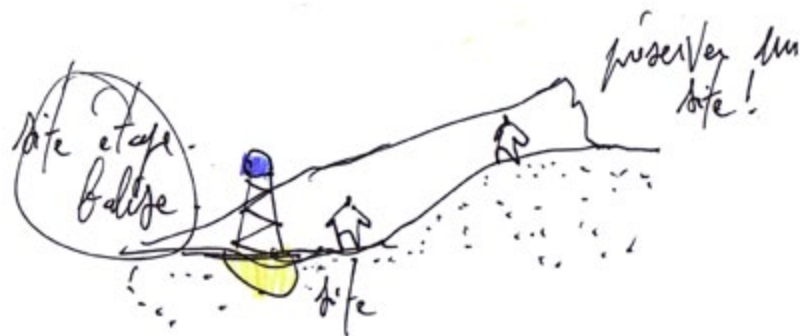

Varen, Montrozier, Féneyrols, Saut du Loup ...

Pour chaque site : *imaginer des seuils visibles, des appels d'air ... visuels*

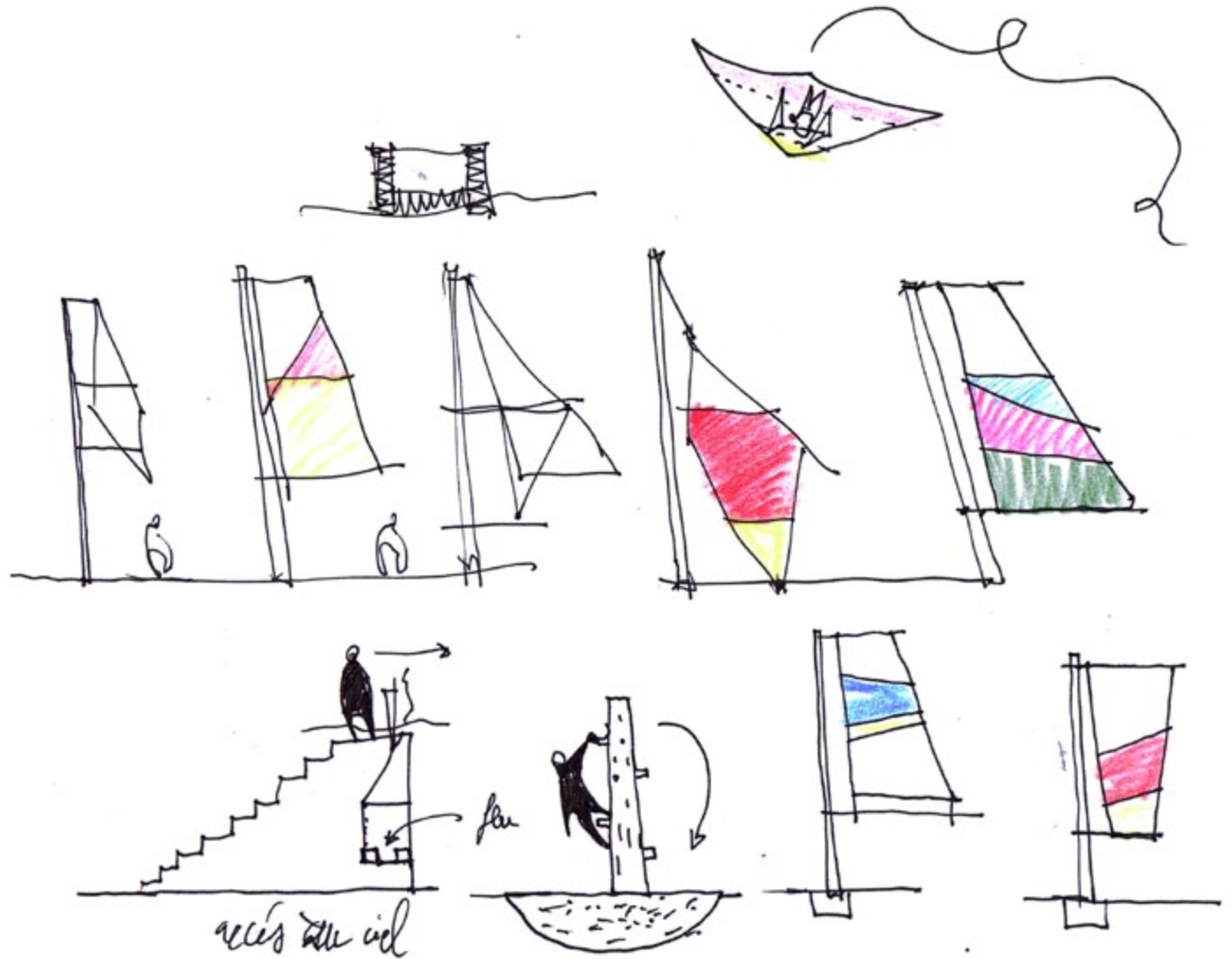

Modulations-déclinaisons : immersion, voiles, escaliers, échelles, flottaison...

site "phares"

- figure type groupe
- scène, théâtre
- sentier de découverte, école
- forains.

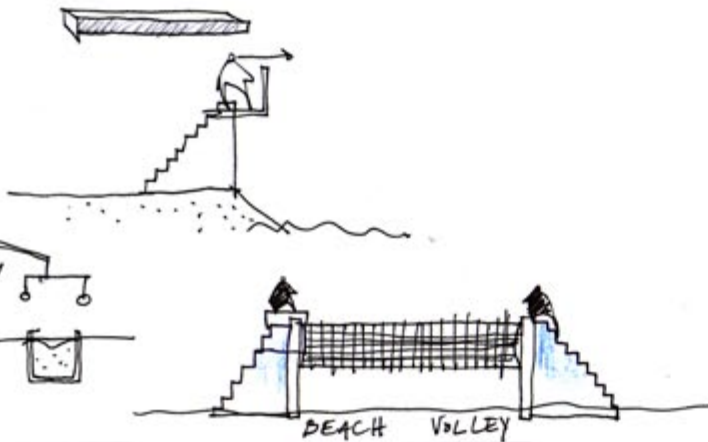
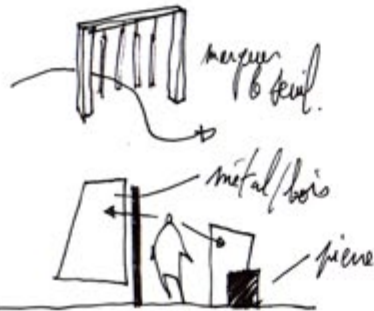

sites "bivouacs-étape"

- modulable.
- mystère
- léger

REGARDER
REPÉRER

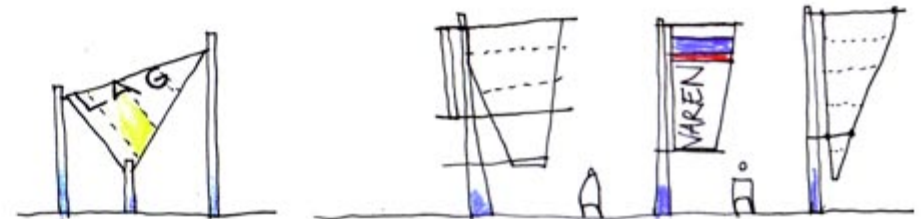
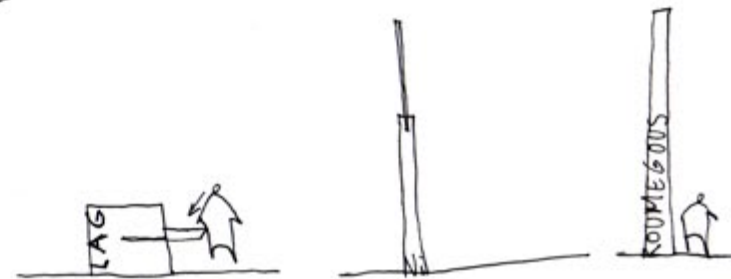
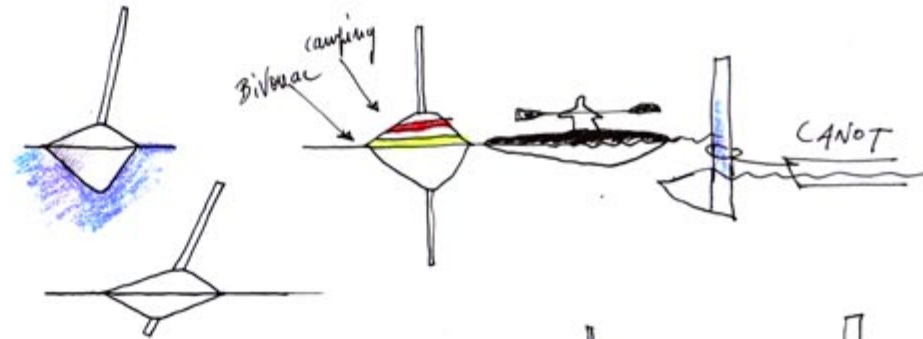
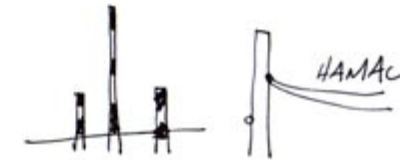

Charte graphique - couleurs et pictogrammes : immersion, voile, escalier, échelle, flottaison...

JEUX

TOILETTES / DOUCHES

GESTION ECOLOGIQUE

pique nique / barbecue

SPECTACLES / ECRANS / GRAPING

Sofas, Belvédères

niveau d'équipement

TYPE 1
petit, faible position

TYPE 2

TYPE 3
gros équipement

2 types de sites

des sites moins étendus
plus naturels, plus préservés
INTIMISTE

des sites plus étendus
PUBLIQUE & LUDIQUE

à superposer, à croiser ou à légènder par des pictogrammes

Variantes : repères, mâts, voiles, oriflammes...

amorce, marque Motrice

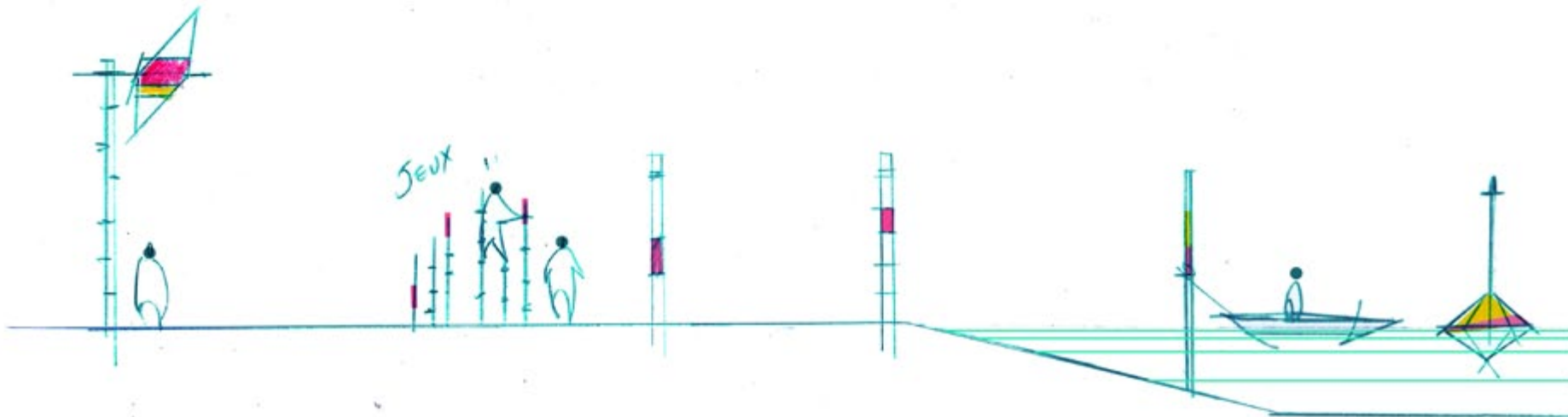
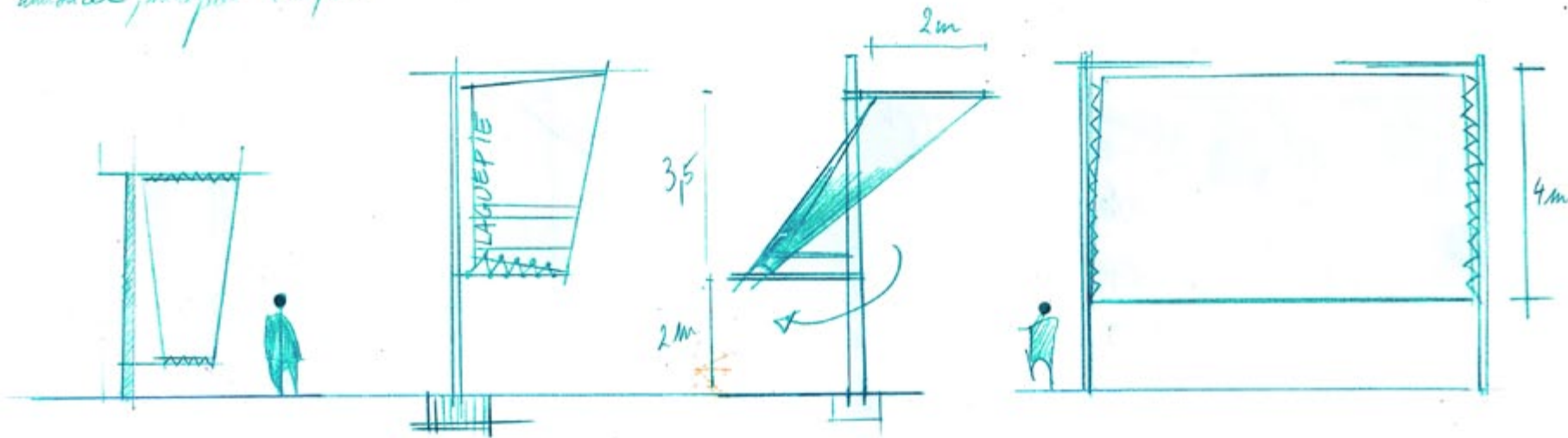

Esquisses : signalétique, perches de repère...

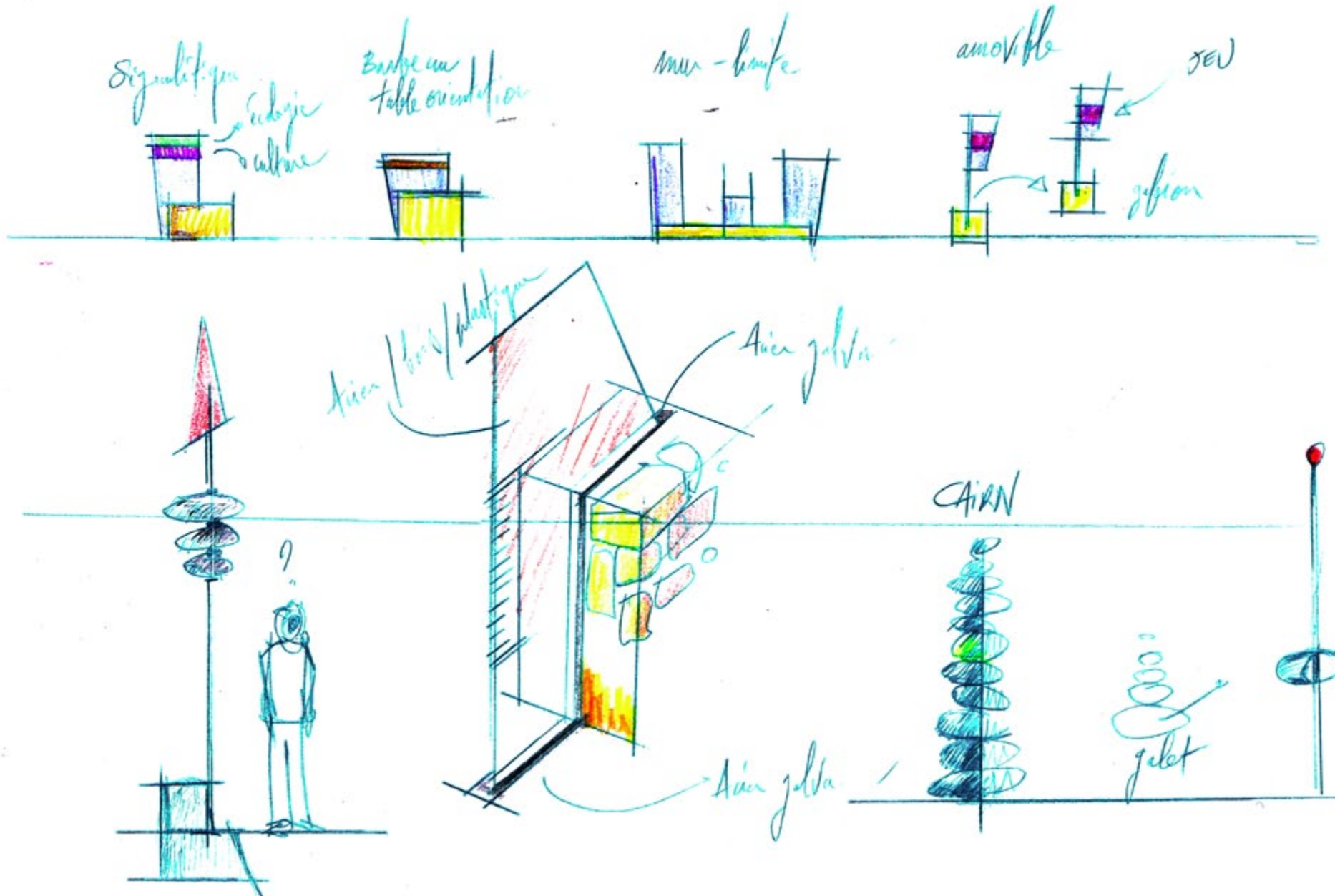

Esquisses : variations sur lignes ou modules

TRIANGULATION

++ + + +

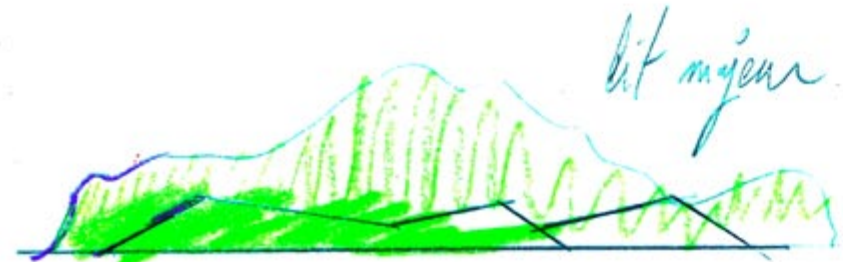
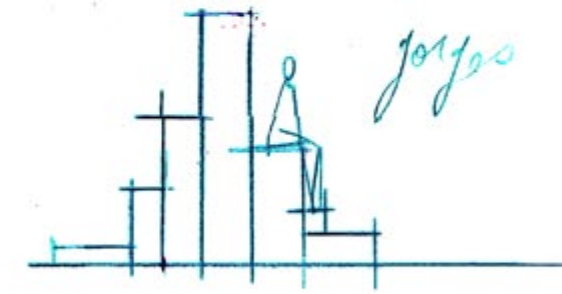
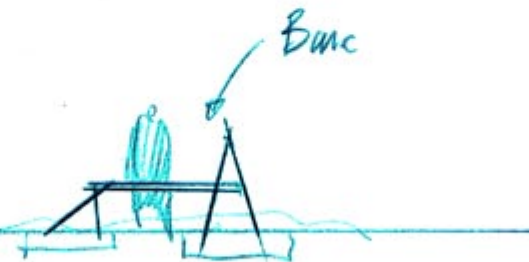
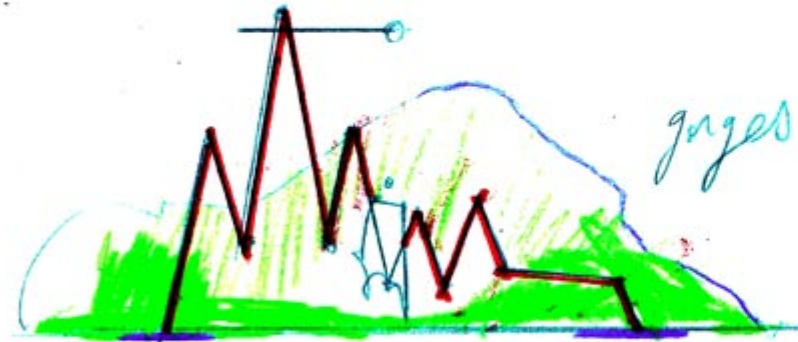
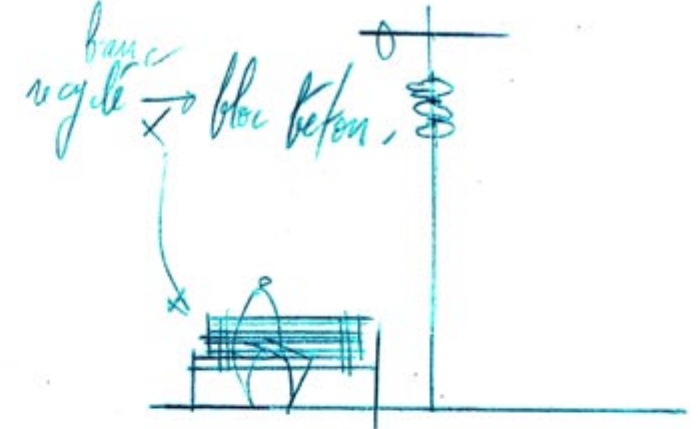
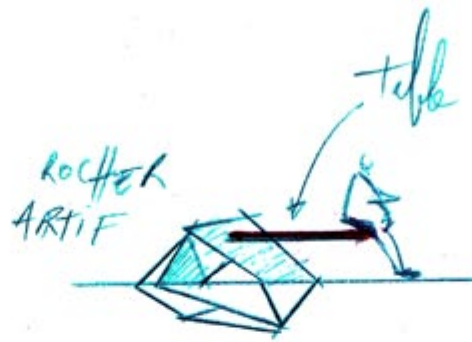
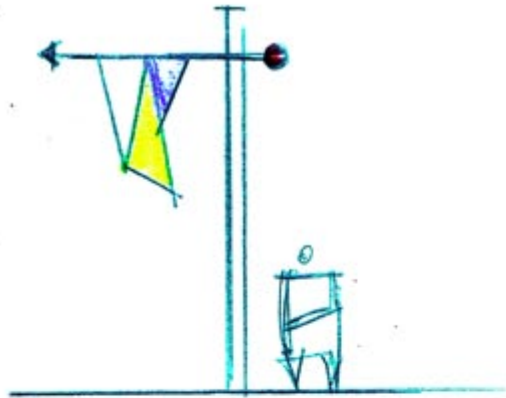

Exemples de mise en situation : *signalétique, mobilier, perches de repère...*



CAZALS



PARISOT



ST ANTONIN



SAUT DU LOUP

Inventer une déclinaison de mobilier

à l'image d'un jardin de territoire

Micro-architectures existantes

Objets de sites

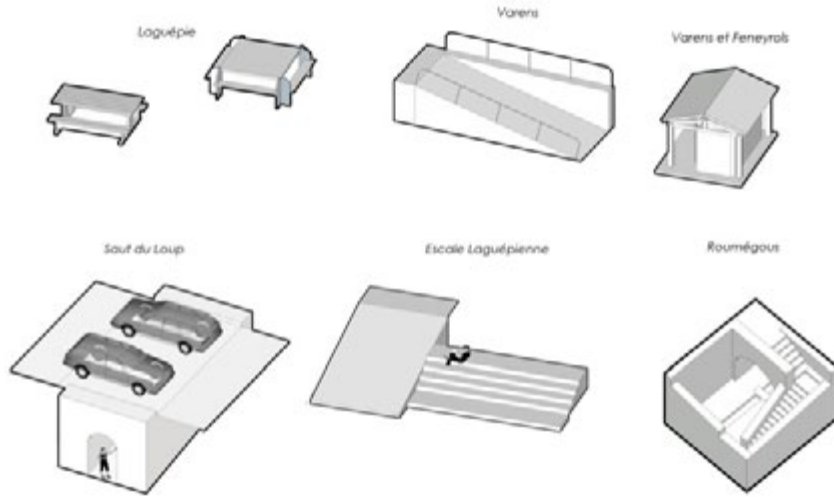

Les folies paysagères du parc de la Villette, Paris

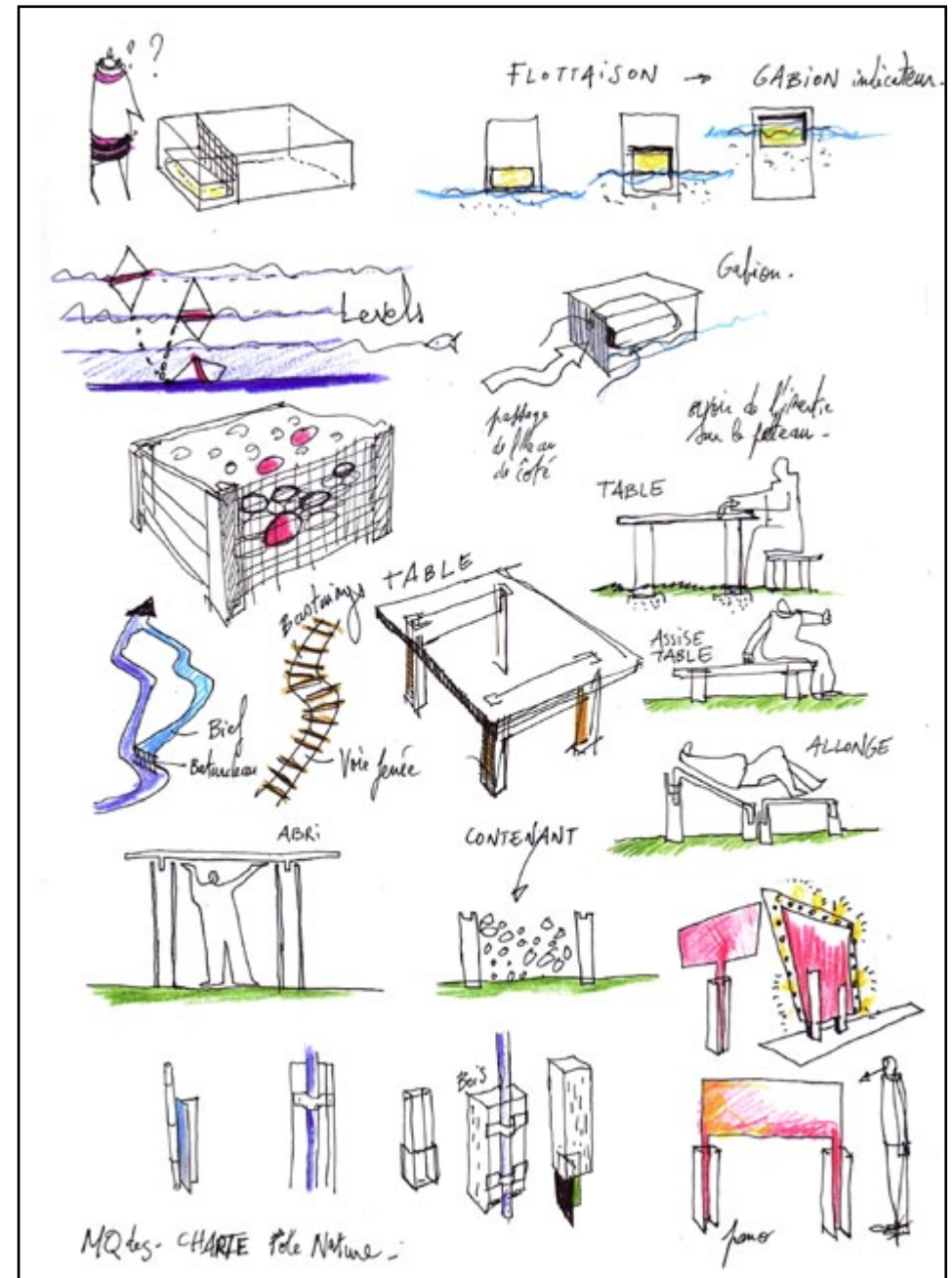
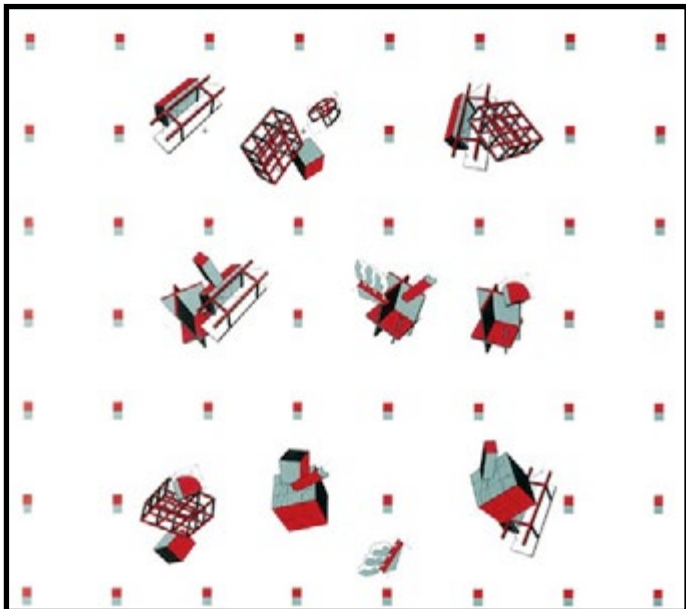

une ligne de mobilier...

à l'image d'un jardin de territoire

NOTES - 10/10/16 -

NOTES - 10/10/16



aisée à construire
et à réparer

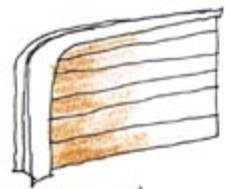

BOIS
+
MÉTAL

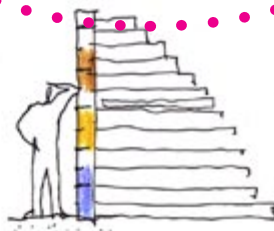
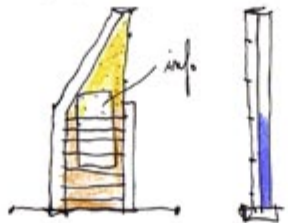
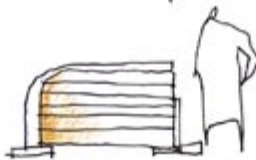

de hauteur

IPN
ACIER
+
TUBE
ACIER



ou

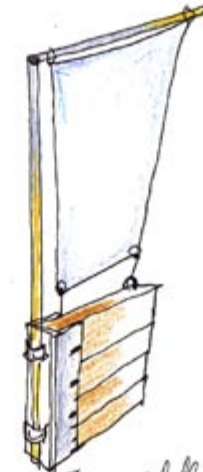

échelle

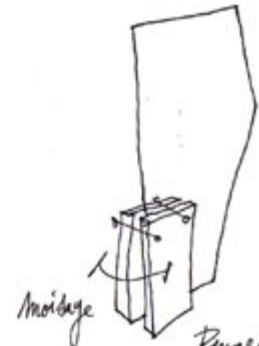

Moidage

Panneau
+
BOIS

PLANCHE POTEAU



BASTING

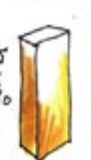

POUTRE
30x30

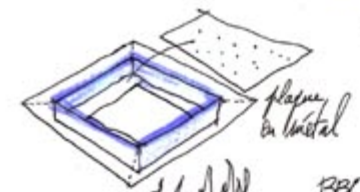
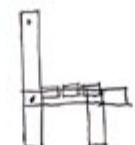
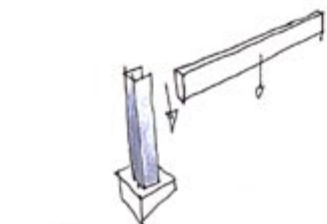

plaque
en cristal

BBQ

Pierre posée
Pierre posée
Pierre calée

STORAGE
BOIS



tube



caping



gilet



1/2 rocher



rocher.

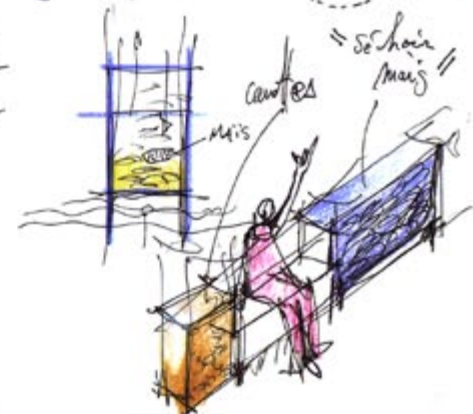

sechoir
maïs

LE PAYSAGE =

- l'utile et l'agréable
- le reflet d'une activité
- le reflet d'une stratégie politique partagée.

THEMAS

la voie ferrée - la rivière - l'agriculture -

meubler de territoire

la fontaine
métallique

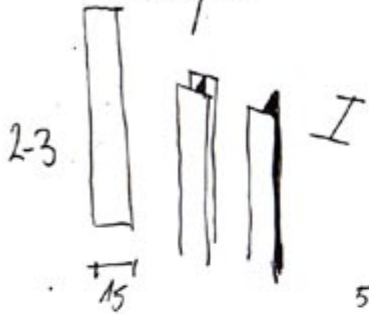

la cage

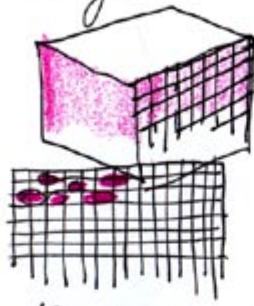

le petit bastion

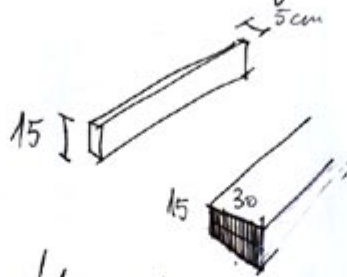

la poutre de bois

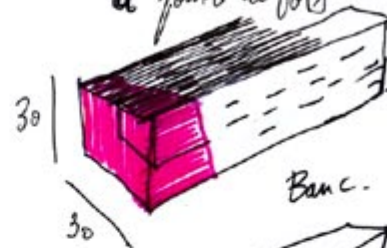

le tube



l'horizontalité
verticalité

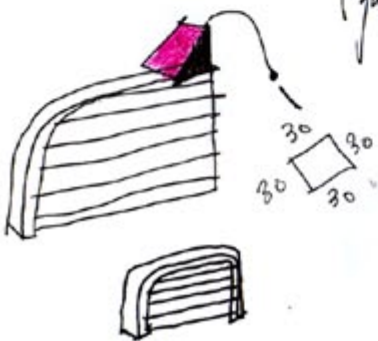
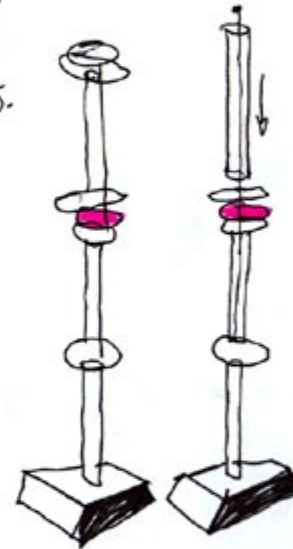
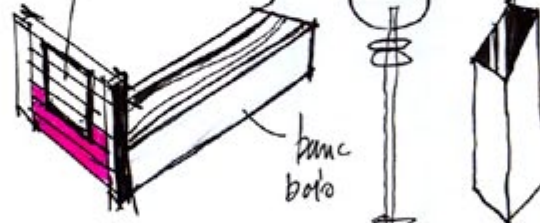
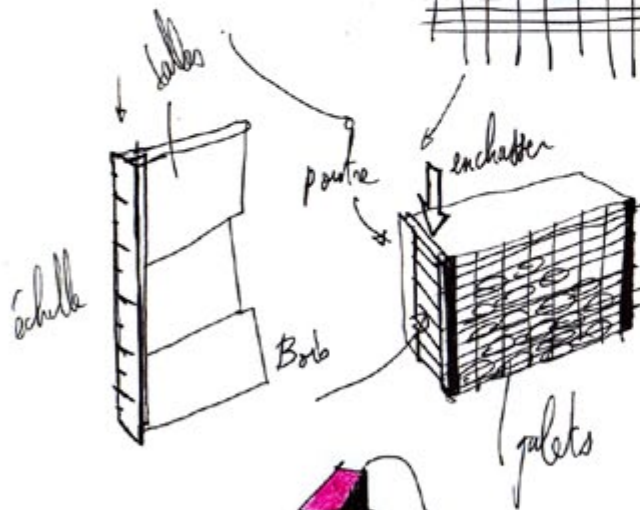
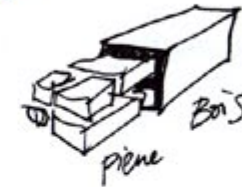

ABRI

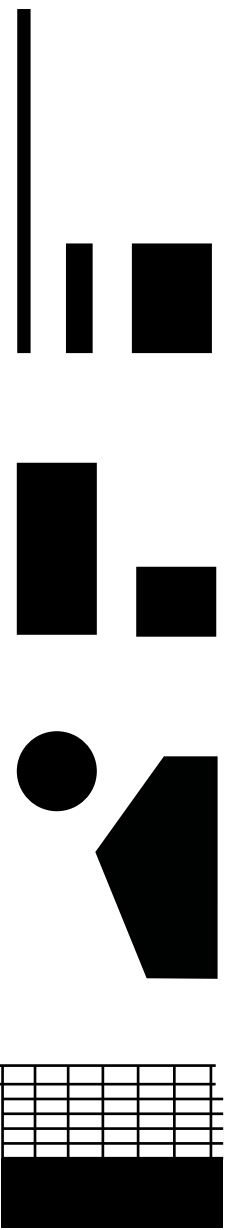
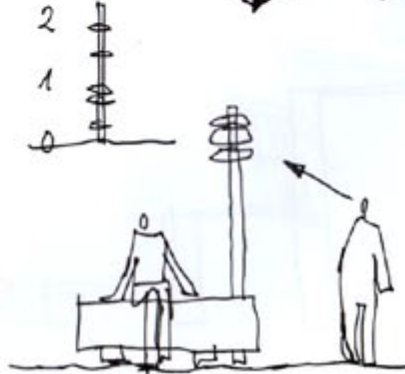
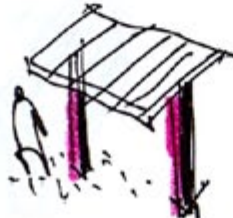

Tolérance aux évolutions.

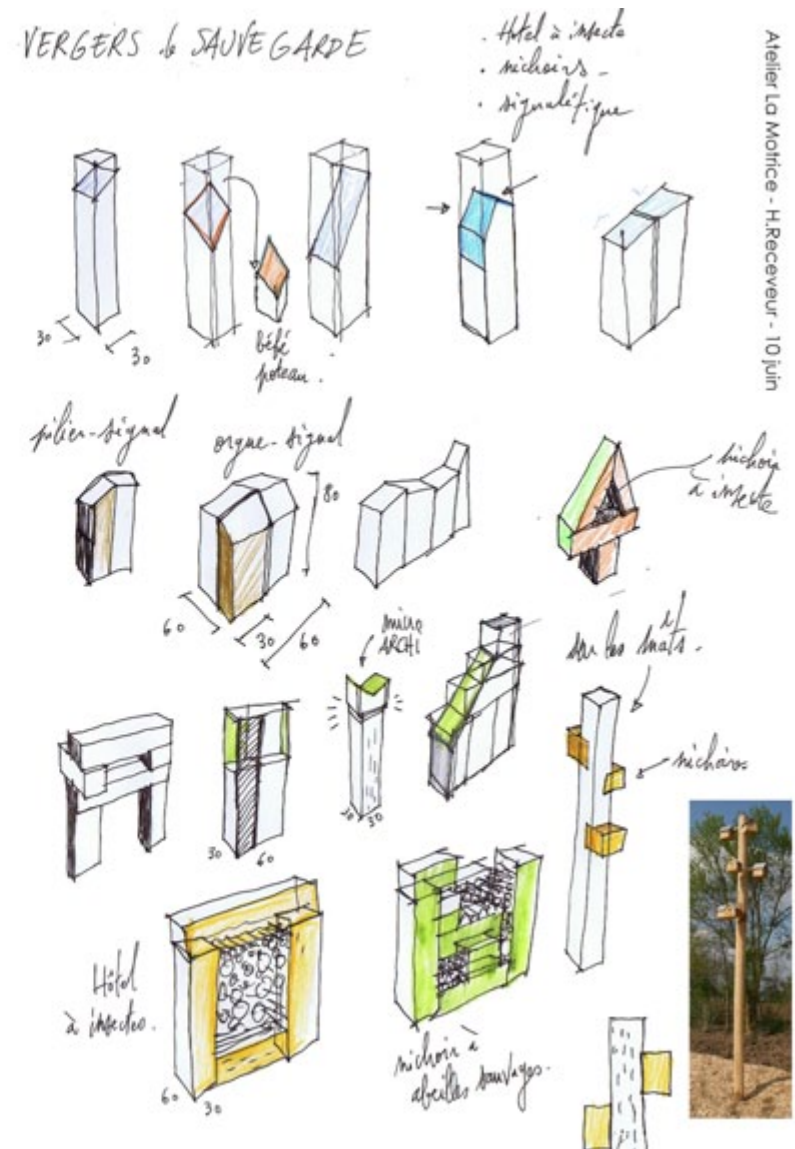
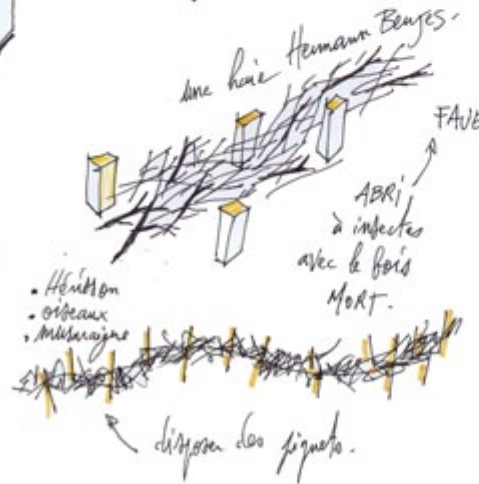
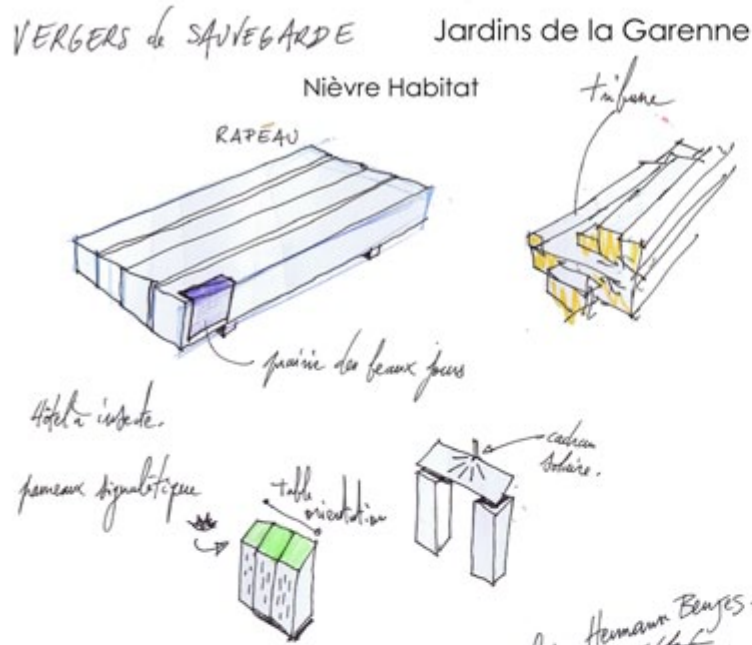

Atelier La Motrice - H.Receveur - 10 juin

exemple mobilier
Parc Ecocité
La Garenne

LA MOTRICE

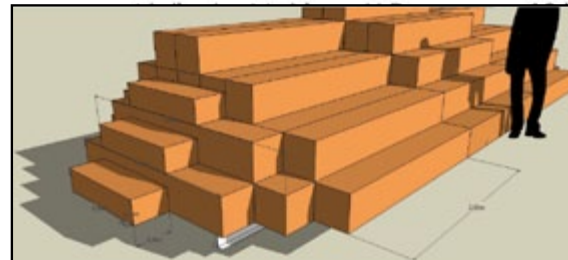

in 2016

mobilier décliné à partir d'un modèle de poutre en chêne